

### TONE RINGER FOR TELEPHONE

- Small Current Consumption.
- Oscillation Frequency Variable.
- Built-in Threshold Circuits Prevent False Triggering due to Power Noise as Well as 'Chirp' by Rotary Dialling.
- Few External Components.

### MAXIMUM RATINGS (Ta=25°C)

CHARACTERISTIC	SYMBOL	RATING	UNIT
Power Supply Voltage	V <sub>CC</sub>	30	V
Power Dissipation	P Type	500	mW
	F Type	350	
Operating Temperature	T <sub>opr</sub>	-30~75	°C
Storage Temperature	T <sub>stg</sub>	-55~150	°C

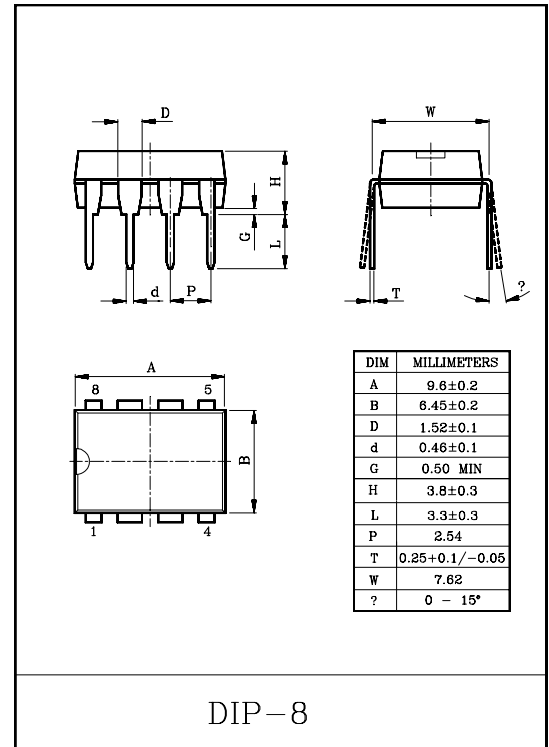

### BLOCK DIAGRAM

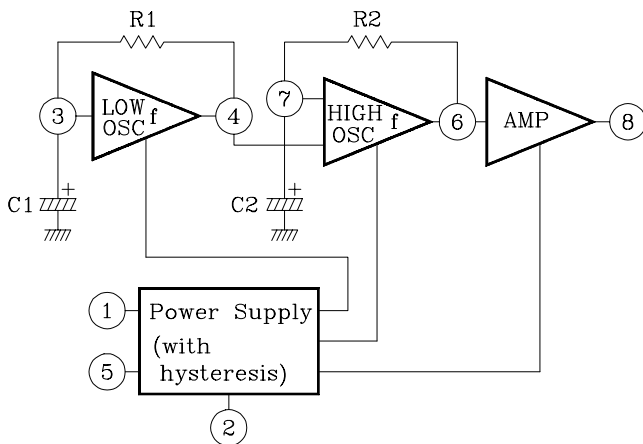

Note: R1,R2,C1, and C2 are parts externally mounted.

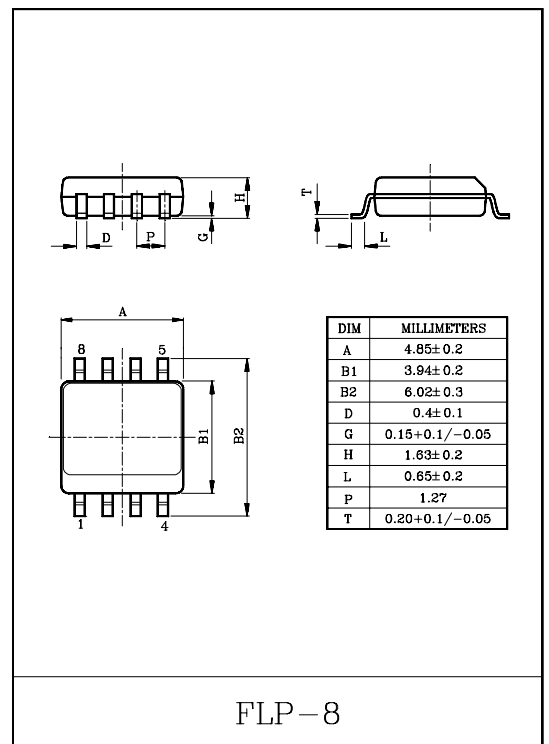

# KIA6401P/F, KIA6402P/F

## PIN CONNECTION

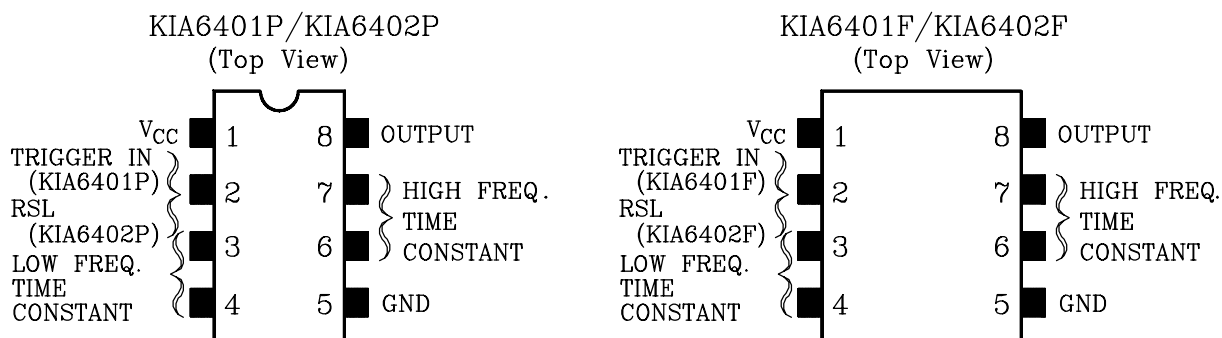

## ELECTRICAL CHARACTERISTICS (Ta=25°C)

CHARACTERISTICS	SYMBOL	TEST CIRCUIT	TEST CONDITION	MIN.	TYP.	MAX.	UNIT	
Operating Voltage	V <sub>OPR</sub>	-		-	-	29	V	
Initiation Supply Voltage	V <sub>SI</sub>	-	(Note 1)	17	19	21	V	
Sustaining Supply Voltage	V <sub>SUS</sub>	-	(Note 2)	10.5	12	-	V	
Initiation Current Consumption	I <sub>SI</sub>	-	No Load	1.4	3.3	4.2	mA	
Sustaining Current Consumption	I <sub>SUS</sub>	-		0.7	1.4	2.5		
Oscillation Frequency (Note 3)	f <sub>L</sub>	-	C <sub>1</sub> =0.47μF, R <sub>1</sub> =165kΩ	9	10	11	Hz	
	f <sub>H1</sub>	-	C <sub>2</sub> =6800pF, R <sub>2</sub> =191kΩ	461	512	563		
	f <sub>H2</sub>	-		576	640	703		
Output Voltage	"H" Level	V <sub>OH</sub>	-	V <sub>CC</sub> =24V, I <sub>OH</sub> =-10mA PIN 7=GND	20.0	21.5	22.5	V
	"L" Level	V <sub>OL</sub>	-	V <sub>CC</sub> =24V, I <sub>OL</sub> =10mA PIN 7=7V	0.7	1.0	2.0	
Trigger IN Terminal Operating Voltage (KIA6401P/F)	V <sub>Trig</sub>	-	V <sub>CC</sub> =15V, I(PIN)=100μA	7.8	10	11.5	V	

Note 1. Initiation Supply Voltage (V<sub>si</sub>) is a supply voltage required to start oscillation of the tone ringer.

2. Sustaining Supply Voltage (V<sub>sus</sub>) is a supply voltage required to maintain oscillation of the tone ringer.

3. Oscillation frequency is determined by the following equations 1,2, and 3:

$$(1) f_L = 1/1.234 \cdot R_1 \cdot C_1 \text{ (Hz)} \quad (2) f_{H1} = 1/1.515 \cdot R_2 \cdot C_2 \text{ (Hz)} \quad (3) f_{H2} = 1.24 \cdot f_{H1} \text{ (Hz)}$$

# KIA6401P/F, KIA6402P/F

## METHOD OF USING PIN ②

### 1.KIA6401P/F METHOD OF USING TRIGGER IN

Usually PIN ② is used at an open state, but in the KIA6401P/F the TRIGGER IN terminal can prohibit oscillation and also can change the initiation supply voltage ( $V_{si}$ ). When the KIA6401P/F is oscillating ( $V_{sus} < V_s$ ), if PIN② is connected to GND as shown in Fig. 1a, the KIA6401P/F can stop oscillating. Further, the oscillation of the KIA6401P/F can be stopped by connecting PIN② to voltage  $V_I$  through the resistor  $R_I$  as shown in Fig. 1b.

In case of  $V_{sus} < V_s - V_{si}$ , the oscillation of the KIA6401P/F can be started by forcing a current  $I_E$  ( $4\mu A < I_E < 1mA$ ) into PIN②.

Oscillation can be started under a lower supply voltage than the initiation supply voltage at the time when PIN② is used at an open state as shown in Fig. 2a. Further, the initiation supply voltage ( $V_{si}$ ) can be changed by using a zener diode as shown in Fig. 2b.

$V_{si}$  is determined by the following formula:

$$V_{si} = V_{Trig} + V_z + 4R_E$$

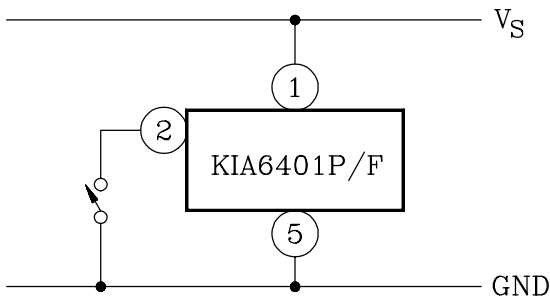

Fig. 1a

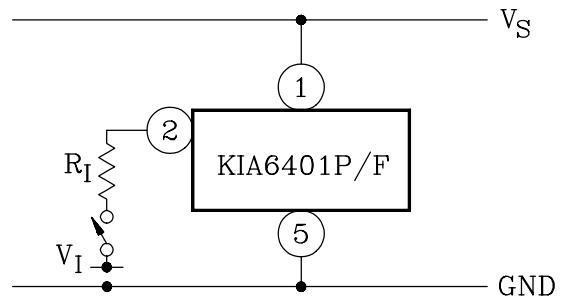
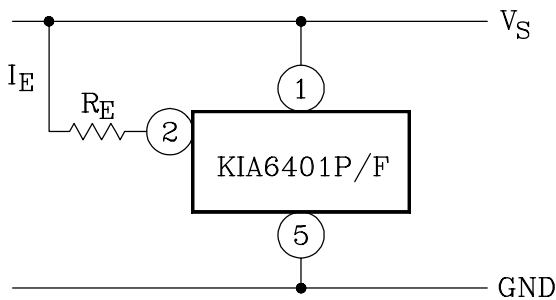

Fig. 1b  $0 \leq V_I \leq 0.5V$   
 $0 \leq R_I \leq 20k\Omega$



$$10k\Omega < R_E < \frac{(V_S - 10)}{4} \text{ (M}\Omega\text{)}$$

Fig. 2a

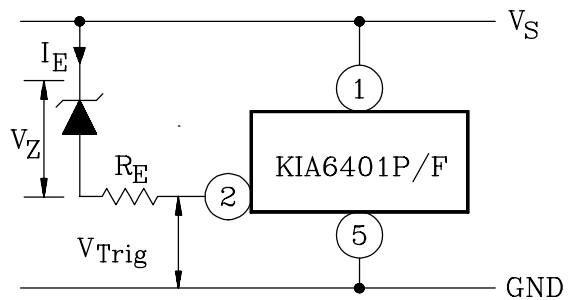

Fig. 2b

# KIA6401P/F, KIA6402P/F

## 2. KIA6402P/F METHOD OF USING R<sub>SL</sub>

In the KIA6402P/F the initiation supply current ( $I_{Si}$ ) can be changed by using the  $R_{SL}$  terminal. The resistor  $R_{SL}$  is connected to GND from PIN② as shown in Fig. 3.

Further, the initiation supply current ( $I_{Si}$ ) can be changed by changing the value of  $R_{SL}$ . Fig. 4 shows the graph of  $V_S$ - $I_S$  characteristic at the time when  $R_{SL}$  has been changed to three values. The  $V_S$ - $I_S$  characteristic at the time when  $R_{SL}=6.8k\Omega$  coincides with that at the time when PIN② of the KIA6401P/F has been used at an open state.

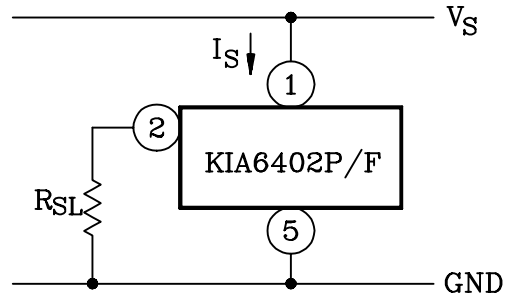
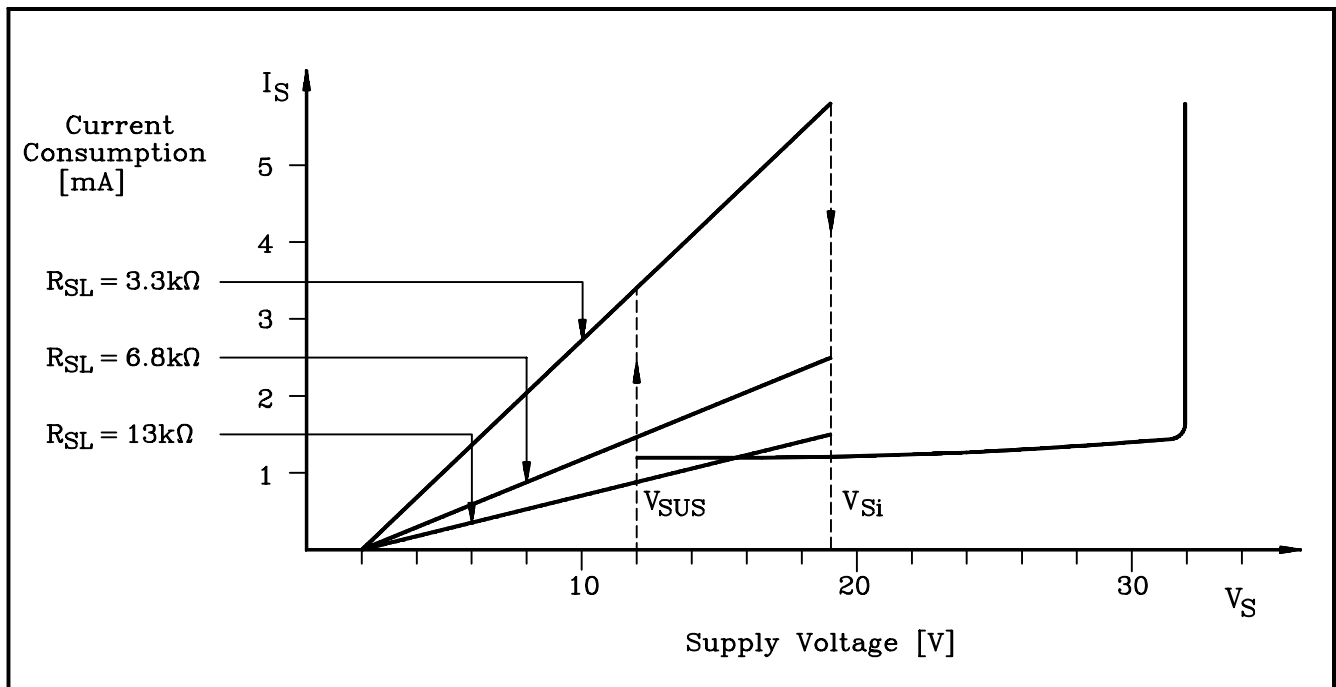

Fig. 3

## KIA6402P/F SUPPLY VOLTAGE – CURRENT CONSUMPTION



# KIA6401P/F, KIA6402P/F

## APPLICATION CIRCUIT OF TONE RINGER

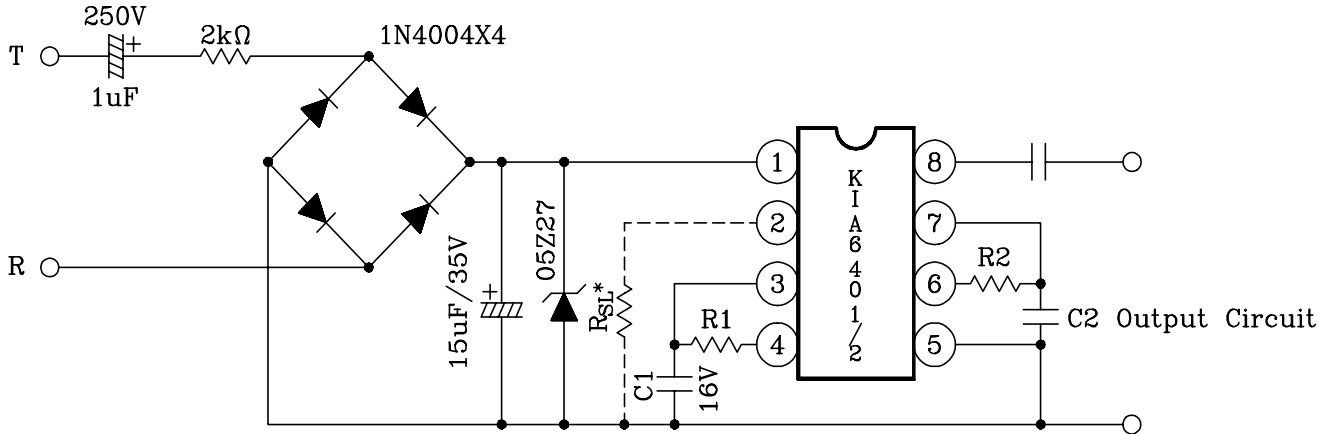

\* Use for KIA6402P/F

$$R1, C1 \quad f_L = 1/1.234 \cdot R1 \cdot C1$$

$$f_{H1} = 1/1.515 \cdot R2 \cdot C2$$

$$f_{H2} = 1.24 f_{H1}$$

\* Example  $R1 = 165k\Omega$        $R2 = 191k\Omega$   
 $C1 = 0.47\mu F$        $C2 = 0.0068\mu F$

$$f_{Low} \approx 10\text{Hz} \quad f_{H1GH1} \approx 500\text{Hz}$$

$$f_{H1GH2} \approx 630\text{Hz}$$

Example of Output Circuit

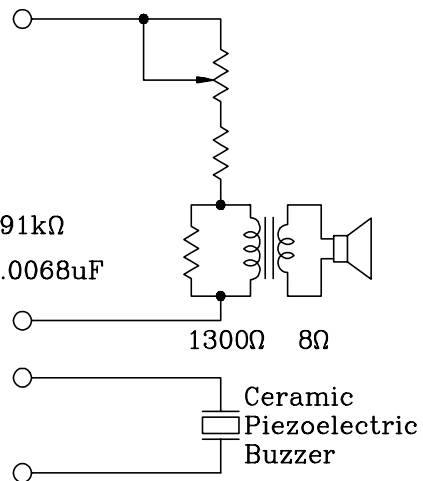

This datasheet has been downloaded from:

[www.DatasheetCatalog.com](http://www.DatasheetCatalog.com)

Datasheets for electronic components.